

Phosphorescence of Benzocyclanones. Probable Origin of the Anomalous Phosphorescence of 1-Indanone¹

Y. Kanda,² J. Stanislaus,³ and E. C. Lim

Contribution from the Department of Chemistry, Loyola University, Chicago, Illinois, and the Department of Chemistry, Wayne State University, Detroit, Michigan. Received March 22, 1969

Abstract: The anomalous "dual" phosphorescence of 1-indanone, reported by Yang and Murov, has been subjected to a detailed study. The emission appears to be composed of not two, but three, components. Two components (band 1 system) have identical spectra but different lifetimes, and they can be spectrally identified with $\pi^* \rightarrow n$ phosphorescence of 1-indanone. The third component (band 2 system) has its origin at the lower energy side of the 0,0 band of the band 1 system, and it appears strongly only in basic solvents. The excitation spectra of the band 1 and band 2 systems are very similar in gross features, but they differ in detail. Both the polarization data and the vibrational progression suggest that the emitting state for the band 2 system is an n, π^* type. 2,2-Dimethyl-1-indanone, which does not possess hydrogen atoms attached to the α -carbon atom, does not exhibit an emission corresponding to the band 2 system of 1-indanone. It is proposed from these and other results that the band 2 system arises from the enolate anions formed from acid-base equilibria (mostly in the excited state), and the slow component of the band 1 system is due to 1-indanone formed from the reketonization of the enolate anions in the lowest triplet state. The emission behavior of 5-fluoro-1-indanone is very similar to that of 1-indanone, while 5-hydroxy- and 5-cyano-1-indanone do not exhibit the emission we ascribe to the enolate anions.

Phosphorescence of 1-indanone was first reported by Yang and Murov⁴ who found that the compound exhibits two groups of emission having different lifetimes in rigid glasses at 77°K. One had a mean lifetime of 2.2 msec in EPA and 1.5 msec in methylcyclohexane, and the other had a mean lifetime of 230 msec in EPA and 150 msec in methylcyclohexane. The excitation spectra of both of these emissions were the same and they corresponded to the absorption spectrum of 1-indanone. Yang and Murov assigned the short-lived emission, possessing vibrational progression of carbonyl stretching frequency (1700 cm^{-1}), to the n, π^* triplet state and tentatively associated the long-lived emission to a triplet state of mixed n, π^* and π, π^* character. This interpretation, if correct, leads to a serious conclusion that the internal conversion between the triplet states is slow enough to allow the occurrence of emission from two triplet states of the same emission center (molecule plus environment) or that there are two different molecular environments (or sites) leading to the two kinds of emission centers with different triplet (emitting) states. The former conclusion is clearly unrealistic in view of the rapidity of the internal conversion, while the latter is thought to be unlikely since the phenomenon of "dual" phosphorescence occurs even in one-component solvent where molecular environments of the solute must be reasonably uniform. It was therefore felt that the longer lived emission may very well be due to a new chemical species, such as an enol or an enolate anion, which can be formed by a reversible photochemical process.

In this paper we present a detailed study of phosphorescence of 1-indanone and related compounds in var-

ious solvents which appears to suggest a probable origin of the anomalous phosphorescence of 1-indanone.

Results

A. Phosphorescence of 1-Indanone and Its Derivatives. Figure 1 shows phosphorescence of 1-indanone in 3MP, MCH, and EPA glasses at 77°K. As can be seen from the figure, the spectral appearance is very similar in all solvents, except that the intensities of the bands marked by longer bars (hereafter designated as the band 2 system) are considerably stronger in EPA than in hydrocarbon solvents. When the EPA spectrum was studied using a phosphoroscope, the intensities of the band 2 system increased relative to those of other bands (hereafter called band 1 system), and at a very slow rotation the band 2 system became more intense than the band 1 system. The results, illustrated in Figure 2, confirm the results of Yang and Murov,⁴ and they indicate the occurrence of two emissions of differing lifetimes. The decay curve of phosphorescence is, as expected, nonexponential in EPA glass (Table I) but exponential in 3MP glass with a mean life-

Table I. Phosphorescence Lifetimes of Benzocyclanones at 77°K

Compd	Lifetime, msec	
	3MP	EPA
1-Indanone	1.5	Nonexponential 1-100
2,2-Dimethyl-1-indanone	1.7	1.9
1-Tetralone	2.9	3.8
2,2-Dimethyl-1-tetralone	2.6	3.7

time of *ca.* 1.5 msec at 77°K. The appearance of the anomalous phosphorescence was independent of the source of 1-indanone, and all three samples (synthetic and commercial) of 1-indanone displayed identical emission behavior.

The phenomenon of "dual" phosphorescence was also detected in 5-fluoro-1-indanone, but 5-hydroxy- and

(1) Correspondence regarding this paper should be addressed to E. C. Lim, Department of Chemistry, Wayne State University, Detroit, Mich. 48202.

(2) National Science Foundation Senior Foreign Scientist Fellow from the Department of Chemistry, Kyushu University, Fukuoka, Japan.

(3) A part of thesis work.

(4) N. C. Yang and S. Murov, *J. Chem. Phys.*, **45**, 4358 (1966).

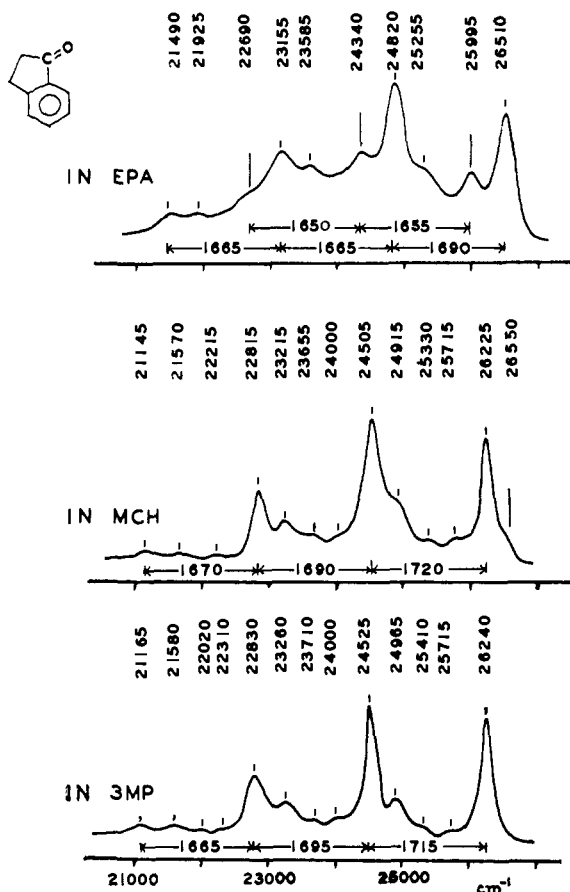

Figure 1. Phosphorescence spectra of 1-indanone in various solvents at 77°K.

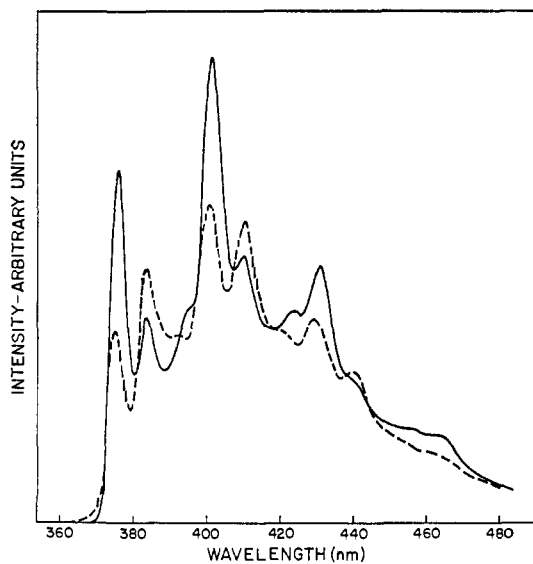

Figure 2. Phosphorescence spectra of 1-indanone in EPA glass at 77°K: (—) spectrum obtained using fast (1800 rpm) rotation of phosphoroscope; (---) spectrum obtained using slow (300 rpm) rotation of phosphoroscope.

5-cyano-1-indanone, which possess a lowest triplet state of π, π^* character, showed no "dual" phosphorescence.

There are two experimental results which indicate that the band 1 system contains a slow decaying component. These are the observations that the band 1 system of the EPA spectrum shows (while the 3MP

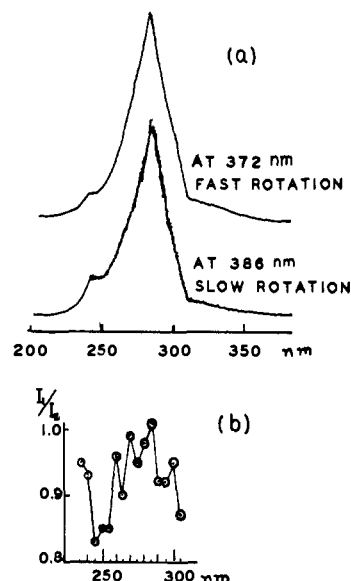

Figure 3. (a) Low-resolution excitation spectra of phosphorescence of 1-indanone in EPA glass at 77°K. (b) Ratio of intensities of the 372-nm and 386-nm emission bands, I_1/I_2 , plotted as a function of the excitation wavelength.

does not) considerable intensity even when the spectrum is studied using very slow rotation of phosphoroscope, and the observation that the decay curve of the individual vibronic bands of the band 1 system is nonexponential and contains a slow decaying tail. Since the solvent dependence (*e.g.*, EPA *vs.* 3MP) of the phosphorescence lifetime is rather small for other molecules (see Table I) the above results indicate the presence of a long-lived component in the band 1 system. Thus, phosphorescence of 1-indanone in EPA glass appears to be composed of three components: short-lived band 1 system, long-lived band 1 system, and the band 2 system.

B. Comparison of the Excitation Spectra of the Band 1 and Band 2 Systems. The excitation spectra of phosphorescence of 1-indanone in EPA glass at 77°K were obtained using a phosphoroscope and they are shown in Figure 2a. Curve 1 represents the excitation spectrum of the 372-nm emission band (assumed to be the 0,0 band of the band 1 system) obtained using fast rotation of the phosphoroscope, while curve 2 is the excitation spectrum of the 386-nm emission band (assumed to be the 0,0 band of the band 2 system) obtained using slow rotation of the phosphoroscope. Although the two excitation spectra appear to be the same at first sight, a close inspection reveals some differences between the two spectra. The most notable of these is the prominence of the shoulder at about 250 nm in the excitation spectrum of the 386-nm emission band relative to that of the 372-nm emission band. In order to ascertain this difference, the phosphorescence spectrum of 1-indanone in EPA glass was studied for different wavelengths of excitation using a constant slow speed of rotation of the phosphoroscope. The ratio of the intensities of the two bands $I_1(372 \text{ nm})/I_2(386 \text{ nm})$ so obtained is plotted against the wavelength of excitation in Figure 3b. The result, which is reproducible, indicates that the excitation spectrum of the band 2 system is different from that of the band 1 system. This conclu-

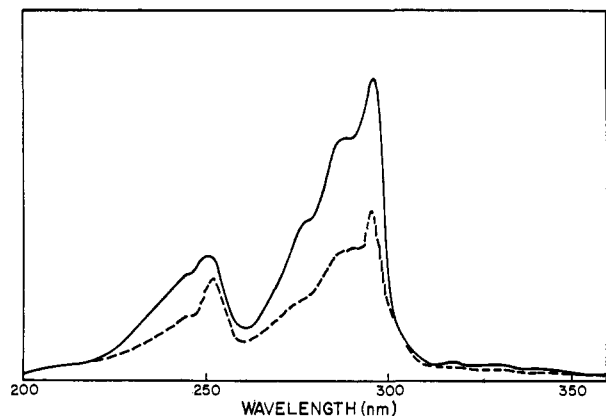

Figure 4. Higher resolution excitation spectra of phosphorescence of 1-indanone in EPA glass at 77°K: (—) excitation spectrum of 372-nm emission band as recorded by using fast (1800 rpm) rotation of phosphoroscope; (---) excitation spectrum of 386-nm emission band as recorded by using slow (300 rpm) rotation of phosphoroscope.

sion is further confirmed by the higher resolution excitation spectra shown in Figure 4.

C. Solvent Dependence of the Band 2 System. As already noted in Figure 1, the intensity of the band 2 system is sensitive to the nature of the solvent. The greater intensity of the emission in EPA relative to 3MP or MCH glass is not due to the hydrogen bonding effect by alcohol since ether and amine give similar enhancement of the emission. Thus, phosphorescence spectra of 1-indanone in EP (1:1 by volume) and TP glasses are essentially the same as those in EPA, PA, and ME glasses. In a series of ether-isopentane mixtures, the emission becomes stronger with increasing amount of ether. For example, the origin of the emission appears as a weak shoulder to the lower energy side of the origin of the band 1 system in 1:9 by volume ether-isopentane mixture, but it appears as a clearly resolved intense band in 3:7 by volume of the same mixture. In 2-methyltetrahydrofuran glass the band 2 system appears particularly strong and the intensity of its 0,0 band, as determined without phosphoroscope, is about 60% of the intensity of the 0,0 band of the band 1 system. The dependence of the band 2 system on the basicity of the solvent is therefore implicated.

D. Vibrational Progression and Polarization of Phosphorescence of 1-Indanone. The band 2 system of 1-indanone in EPA glass at 77°K (Figure 1) exhibits a vibrational progression of 1655 cm^{-1} , while the band 1 system shows a progression of 1690 cm^{-1} which corresponds to the carbonyl-stretching frequency. Both the band 1 and band 2 systems are positively polarized with respect to L_b and L_a excitations in the region of *ca.* 300–220 nm. The result, which is illustrated in Figure 5 for L_b excitation, leads⁵ to the n, π^* assignment for the emitting triplet states of these emission.

E. Phosphorescence of 2,2-Dimethyl-1-indanone, 1-Tetralone, and 2,2-Dimethyl-1-tetralone. Phosphorescence spectra of 2,2-dimethyl-1-indanone in EPA and 3MP glasses at 77°K are shown in Figure 6. The two spectra are nearly identical in shape and no band corresponding to the band 2 system of 1-indanone is ap-

(5) E. C. Lim, Y. Kanda, and J. Stanislaus in "Molecular Luminescence," E. C. Lim, Ed., W. A. Benjamin, Inc., New York, N. Y., 1969, p 111.

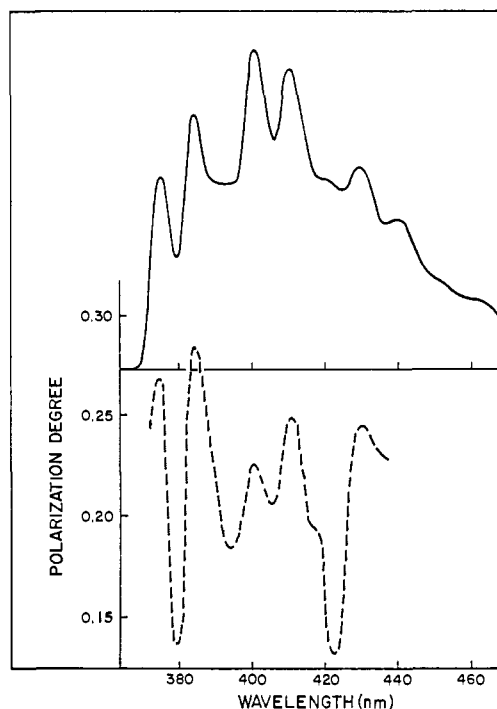

Figure 5. Polarization of phosphorescence of 1-indanone in EPA glass at 77°K. Excitation wavelength: 288 nm; phosphoroscope rotation: slow (300 rpm).

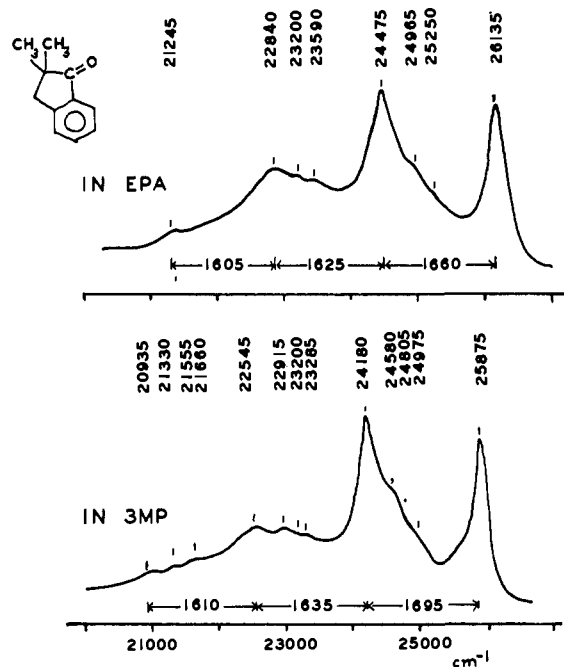

Figure 6. Phosphorescence spectra of 2,2-dimethyl-1-indanone.

parent in the EPA spectrum. The absence of the slow decaying components was also confirmed by the decay curves of phosphorescence which are exponential in both matrices (Table I). Similarly, no "multiple" phosphorescence was observed from 3MP or EPA solutions of 1-tetralone and 2,2-dimethyl-1-tetralone at 77°K. These results are summarized in Figures 5 and 6, and Table I.

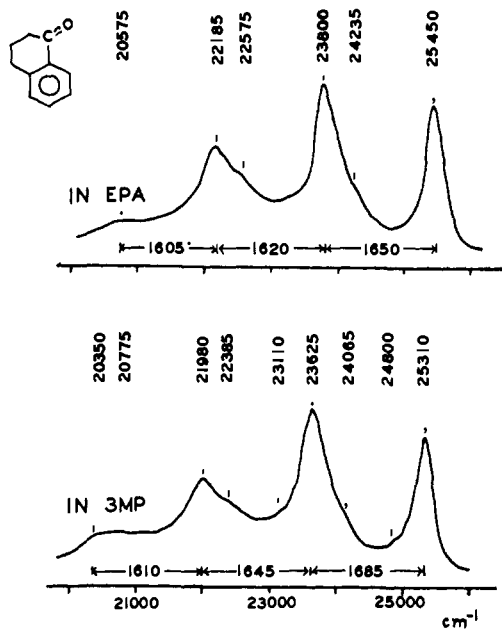

Figure 7. Phosphorescence spectra of 1-tetralone.

Discussion

The present data suggest the occurrence of three different phosphorescences in basic solutions of 1-indanone. The band 1 system (bands marked by short bars in Figure 1) appears to be composed of short-lived (<10 msec) and a minor, long-lived (>10 msec) component, while the band 2 system is predominantly long-lived (>10 msec).

The observation that the excitation spectra of the two band systems are different indicates that these emissions arise from different molecular species. The band 1 system is most certainly the emission from the $^3n, \pi^*$ state of 1-indanone since it is positively polarized with respect to $\pi \rightarrow \pi^*$ excitations, and displays vibrational progression of carbonyl stretching frequency. The dependence of the band 2 system on the basicity of the solvent as well as its absence in 2,2-dimethyl-1-indanone suggests that the band 2 system is probably due to enol or enolate anion. If the emission arises from the enol form of 1-indanone, it should show characteristics of $\pi^* \rightarrow \pi$ phosphorescence both with respect to polarization and vibrational progression since the enol does not possess nonbonding electrons. More specifically, the 0,0 band of the emission should be negatively polarized with respect to $\pi \rightarrow \pi^*$ excitations and the spectrum should show a vibrational progression of indene skeletal vibration at about 1540 cm^{-1} . Thus, both the polarization data (positive polarization degree) and the vibrational progression (1655 cm^{-1}) of the band 2 system appear to rule out the enol form of 1-indanone as the source of the emission. On the other hand, all the emission characteristics of the band 2 system are consistent with the triplet state of the enolate anion as the emitting species.

It is well known that the hydrogen atoms attached to the α position of carbonyl compounds are acidic if there can be charge delocalization from the α -carbon to the carbonyl oxygen.⁶ This requires that the α -carbon be

(6) C. D. Gutsche, "The Chemistry of Carbonyl Compounds," Prentice-Hall, Inc., Englewood Cliffs, N. J., 1967, p 17.

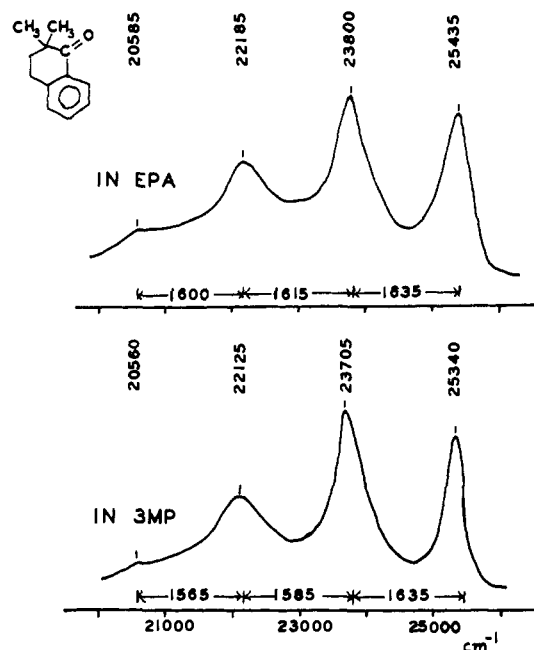
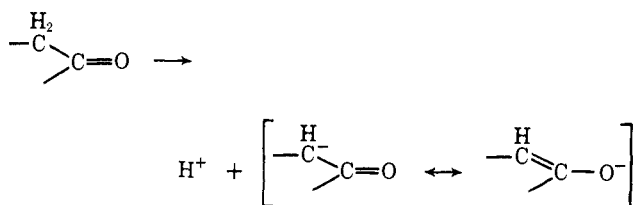
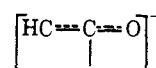

Figure 8. Phosphorescence spectra of 2,2-dimethyl-1-tetralone.

sp^2 hybridized and that the p orbitals on the α -carbon, the carbonyl carbon, and the oxygen become collinear, *i.e.*, that the geometry of the α -carbanion becomes planar. Among benzocyclanones, this requirement is



best met in 1-indanone which is either planar or very nearly planar. As the size of the acyclic ring increases, the electron delocalization over the three-atom system



is expected to decrease due to the less favorable dihedral angle in the acyclic ring. One would therefore expect 1-indanone to be most acidic among benzocyclanones. The enolate anion of 1-indanone can be represented by

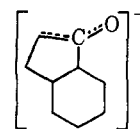

or by the two resonance structures

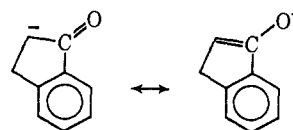

The lowest triplet state of enolate anion can then be of n, π^* type (thus accounting for the positive degree of polarization of the band 2 system) and phosphorescence of the enolate anion is expected to show progression of

C=O stretching vibration which must necessarily be lower in frequency than the C=O stretching mode at about 1700 cm^{-1} .

The observation that the excitation spectrum of the band 2 system is similar (but not identical) to that of the band 1 system, and that it corresponds approximately to the absorption spectrum of 1-indanone, suggests that enolate anions are formed largely in the excited state(s). The increase in the acidity of 1-indanone following photoexcitation can perhaps be rationalized if the excited state involved in the proton dissociation is assumed to be an n, π^* state. The ability of 1-indanone to act as a proton donor is ascribed to electron delocalization from the α -carbon atom to the oxygen, and therefore to the ease of formation of the oxanion. The stability of the oxanion might be expected to increase in the n, π^* state since the promotion of nonbonding (n) electron to an antibonding (π^*) orbital creates an electron deficiency at the carbonyl oxygen atom. Although the same $n \rightarrow \pi^*$ excitation may decrease the stability of the carbanion, the stabilization of the oxanion might more than offset the destabilization since the π^* orbital is extensively delocalized. It may therefore not be unreasonable to expect the acidity of 1-indanone to increase following an $n \rightarrow \pi^*$ excitation.

On the basis of the above considerations and the available data the following mechanism for the appearance of the anomalous emission in 1-indanone may be envisaged.

In the ground state, the equilibrium between 1-indanone and its enolate anion

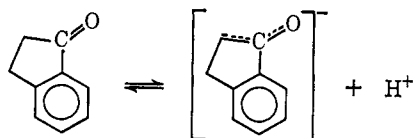

is heavily on the side of the keto form, so that 1-indanone is the predominant species. Upon electronic excitation, a part of the excited 1-indanone dissociates (perhaps in the n, π^* state) to form enolate anion, while a large part emits $\pi^* \rightarrow n$ phosphorescence in the form of the fast component of the band 1 system. The enolate anions formed from the excited-state and the ground-state dissociation can either emit phosphorescence or undergo reketonization in their lowest triplet state. The $\pi^* \rightarrow n$ phosphorescence from the enolate anions is responsible for the emission designated as the band 2 system, while the triplet state of 1-indanone, resulting from the reketonization of the enolate anions, leads to the appearance of the slow decaying component of the band 1 system. A schematic representation of the proposed emission model is shown in Figure 9.

Although the formation of enolate anion is apparently inhibited in hydrocarbon solvents, it is possible that a small fraction of 1-indanone is protonated (as the result of keto enolate anion equilibrium) in the ground state and emits phosphorescence which is different from that of 1-indanone. While there is no spectral evidence for the existence of protonated species in 3MP spectrum, there is a shoulder at about 325 cm^{-1} to the higher energy side of the 0,0 band (of the band 1 system) in the MCH spectrum (see the shoulder marked by a longer bar in Figure 1). The shoulder is probably due to pro-

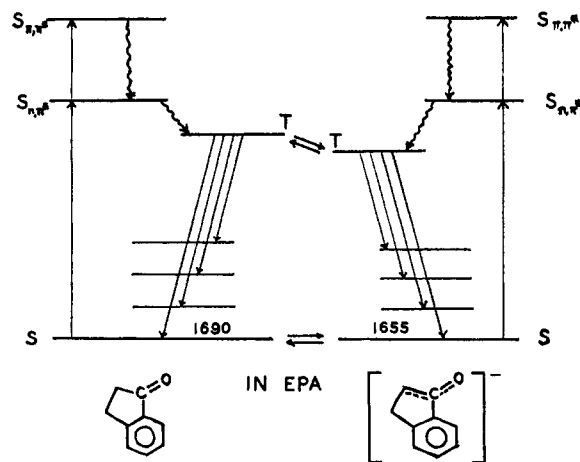
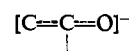

Figure 9. A schematic representation of the proposed emission model for 1-indanone in basic solvents.

tonated 1-indanone since its intensity is greatly enhanced by the addition of a very small amount of trifluoroacetic acid. The greater intensity of the MCH relative to the 3MP spectrum in the region of the band 2 system suggests greater concentration of enolate anion in MCH, and it is also consistent with the assignment of the shoulder to the protonated species.

Returning to a consideration of the reasons for the absence of the anomalous emission in 1-tetralone, it is possible that the conversion of keto form to its enolate anion might depend not only on the ease of electron delocalization over the three-atom system



but also on the energy of the excited state (assumed to be triplet) of the enolate anion being lower than that of the keto form. While this energy requirement is apparently met in 1-indanone, so that the conversion of excited 1-indanone to excited enolate anion is possible, it may not be met in 1-tetralone. In this connection, it is noteworthy that spectral evidence (0,0 band of phosphorescence) indicates that the n, π^* state of 1-tetralone is lower in energy than the n, π^* state of 1-indanone. It is therefore proposed that both the greater planarity of enolate anion and the lower energy of the excited state of enolate anion relative to that of keto form favor proton dissociation in 1-indanone.

Whatever the detailed mechanism may be, the results of the present study show that the anomalous phosphorescence of 1-indanone can be explained on the basis of enolate anions which are assumed to be produced *via* acid-base equilibrium. It is entirely possible that similar anomalous emission also occur in other aromatic ketones in which steric and energetic factors do not preclude formation of enolate anions. In fact, several phenyl alkyl ketones display delayed emission very similar to the band 2 system of 1-indanone.

Experimental Section

Two synthetic and one commercial (Eastman Distillation Products) samples of 1-indanone were used in this study. A synthetic scheme was based on the cyclization of hydrocinnamoyl chloride in the presence of AlCl_3 ,⁷ while the other involved reaction between

(7) A. Rahman and A. E. Gastaminza, *Rec. Trav. Chim.*, **81**, 645 (1962).

AlCl_3 and β -chloropropiophenone which was obtained from benzene, β -chloropropionyl chloride, and AlCl_3 .⁸ These samples were purified either by recrystallization from ethanol-methylcyclohexane mixture or by steam distillation followed by chromatography using a column of alumina and/or silica gel. 1-Tetralone was obtained from Eastman Distillation Products and it was purified through steam distillation and recrystallization from water. 2,2-Dimethyl-1-indanone and 2,2-dimethyl-1-tetralone were prepared from their respective benzocyclonones following the procedure of Haller and Bauer.⁹ All derivatives of 1-indanone were obtained from Norman L. Allinger of Wayne State University and they were purified by vacuum sublimation or distillation. The solvents used for the emission studies were 3MP (3-methylpentane), EPA (5:5:2 by volume of ether, isopentane, and alcohol), EP (1:9, 3:7, and 1:1 by volume

(8) B. Amagat, *Bull. Soc. Chim.*, **41**, 940 (1927).

(9) A. Haller and E. Bauer, *Compt. Rend.*, **150**, 1475 (1910).

of ether and isopentane), MCH (methylcyclohexane), TP (1:1 by volume of triethylamine and isopentane), MTF (2-methyltetrahydrofuran), PA (1:1 by volume of isopentane and ethanol), and ME (1:1 by volume of methanol and ethanol).

The polarization and excitation spectra of phosphorescence were obtained using Aminco-Bowman and Aminco SPF-1000 spectro-photofluorometers, while higher resolution phosphorescence spectra were obtained using a Jarrell-Ash 0.5-m Ebert scanning spectrometer. Recording electronics for the last instrument consisted of an EMI 6255B photomultiplier tube and a Sargent MR recorder. The phosphorescence mean lifetimes were determined using a GE BH-6 mercury arc lamp operating as a flash lamp.

Acknowledgments. We wish to thank Professors Normal Allinger, Carl Johnson, and Harvey Posvic for helpful discussions.

A Comparison of the Photodimerizations of 2-Cyclopentenone and of 2-Cyclohexenone in Acetonitrile^{1a}

Peter J. Wagner^{1b} and David J. Bucheck^{1c}

Contribution from the Chemistry Department, Michigan State University, East Lansing, Michigan 48823. Received March 27, 1969

Abstract: In acetonitrile, head-to-head:head-to-tail photodimer ratios are independent of ketone concentration, being 4:5 for cyclopentenone and 2:1 for cyclohexenone. The variation in dimer quantum yields as a function of ketone concentration indicates k_i/k_a ratios of 0.06 and 2.7, respectively, where k_a is the bimolecular rate constant for reaction of triplet ketone with ground-state ketone and k_i is the rate of unimolecular triplet decay. Stern-Volmer quenching studies with conjugated dienes yield measures of triplet lifetimes as a function of ketone concentration. These studies indicate k_a values of 6.9×10^8 and $1.1 \times 10^8 \text{ M}^{-1} \text{ sec}^{-1}$ and k_i values of 4×10^7 and $3 \times 10^8 \text{ sec}^{-1}$, respectively, for cyclopentenone and cyclohexenone. For both ketones dimerization occurs from the lowest triplet; the more rapid decay rate of the reactive cyclohexenone triplet probably reflects a greater ease of twisting. The maximum efficiency of dimerization is only 36% for cyclopentenone and 74% for cyclohexenone. Since intersystem crossing is 100% efficient for both ketones, these results indicate that both dimerizations proceed through metastable dimeric species, significant percentages of which revert to two ground-state monomers. A comparison of these results with others in the literature suggests that dimerization occurs from π, π^* triplet states.

Photodimerization of α, β -unsaturated cyclic ketones is a well-known process.² Although the reaction is general for many cyclopentenones and cyclohexenones,³ detailed studies have been made only of cyclopentenone (CP),^{4,5} cyclohexenone (CH),⁶ and isophorone.⁷ For all three ketones, *cis-anti*-fused head-to-head and head-to-tail cyclodimers are the principal products and arise solely from the excited triplet states of the ketones. de Mayo and coworkers have suggested that the cycloaddition reactions of cyclopentenone involve the *second* excited triplet, the lowest triplet apparently undergoing only photoreduction.^{8,9} Hammond

and coworkers suggest that cyclohexenone dimerizes from its lowest triplet.⁸ Chapman and coworkers, however, have suggested that isophorone undergoes cycloadditions from two distinct triplets.^{7,10}

The HH/HT dimer ratios increase significantly with solvent polarity for all three ketones. This fact complicates mechanistic studies, since the enones are polar enough that product distributions and thus relative rates are a function of ketone concentration.

Relatively few results have been reported which afford values of the rate constants for the primary reactions of the excited enone triplets. A bimolecular rate constant of $10^6 \text{ M}^{-1} \text{ sec}^{-1}$ has been estimated for the addition of triplet isophorone to ground-state isophorone.⁷ However, quenching studies indicate triplet-state lifetimes of only a few nanoseconds for 3 M cyclopentenone^{4b} and for 1 M cyclohexenone.⁸ Eaton has shown that cycloheptenone and cyclooctenone do not dimerize

(1) (a) Preliminary report: P. J. Wagner and D. J. Bucheck, *Can. J. Chem.*, **47**, 713 (1969); (b) Alfred P. Sloan Fellow, 1968-1970; (c) National Institutes of Health Predoctoral Fellow, 1966-1969.

(2) For a review, see O. L. Chapman and G. Lenz in "Organic Photochemistry," Vol. 1, O. L. Chapman, Ed., Marcel Dekker, Inc., New York, N. Y., 1967, p 283.

(3) W. G. Dauben, G. W. Shaffer, and N. D. Vietmeyer, *J. Org. Chem.*, **33**, 4060 (1968).

(4) (a) P. E. Eaton, *J. Am. Chem. Soc.*, **84**, 2344 (1962); (b) P. E. Eaton and W. S. Hurt, *ibid.*, **88**, 5038 (1966).

(5) J. L. Ruhlen and P. A. Leermakers, *ibid.*, **89**, 4944 (1967).

(6) E. Y. Y. Lam, D. Valentine, and G. S. Hammond, *ibid.*, **89**, 3482 (1967).

(7) O. L. Chapman, P. J. Nelson, R. W. King, D. J. Trecker, and A. A. Griswald, *Record Chem. Progr.*, **28**, 167 (1967).

(8) P. de Mayo, J.-P. Pete, and M. Tchir, *J. Am. Chem. Soc.*, **89**, 5712 (1967).

(9) P. de Mayo, J.-P. Pete, and M. Tchir, *Can. J. Chem.*, **46**, 2535 (1968).

(10) O. L. Chapman, T. H. Koch, F. Klein, P. J. Nelson, and E. L. Brown, *J. Am. Chem. Soc.*, **90**, 1657 (1968).